

GENÇSAN KARDAN

“Energy to the machine”

➔ www.gencsankardan.com

“Hareket halindeki enerji”

Araştırma-Geliştirme ve inovasyon Gençsankardan'ın anahtar değerleridir.

Görevimiz, müşterilerimizin teknik, ticari ve ekonomik gereksinimleri için yenilikçi ve sürekli gelişime açık çözümler üretmektir.

1994 yılından beri, Gençsankardan yüksek teknoloji ve güveni birarada sunar. En iyi sonuçlara müşterilerimiz için, müşterilerimizle ulaşıyoruz.

“Energy to the machine”

Research and innovation are Gencsan Kardan's key values.

Our mission is to create value for our customers, through innovation and the continuous research of the right solution for their technical, commercial or economic exigences.

Since 1994, Gencsan offers high technology and trust. We achive best results with our customers, for our customers.

GENÇSAN KARDAN

G

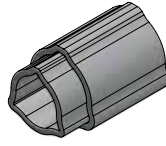

T SERIES

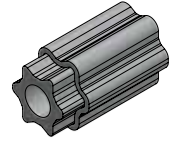

S SERIES

Ölçü Size	İstavroz Cross Kit	Üçgen Boru Dış Triangular Tube Outer	Üçgen Boru İç Triangular Tube Inner	Yıldız Boru Dış Star Tube Outer	Yıldız Boru İç Star Tube Inner
1	101 	T106 	T107 		
2	201 	T206 	T207 		
4	401 	T406 	T407 		
5	501 	T506 	T507 		
6	601 	T606 	T607 	S06 	S07
7	701 	T706 	T707 	S06 	S07
8	801 	T806 	T807 	S06 	S07
9	901 	T906 	T907 	S06 	S07
J	J01 			S05 	S06
L	L01 			S05 	S08

GÜÇ TABLOSU / POWER RATING

SERİ SERIE	540 dev./dak.-rpm				1000 dev./dak.-rpm				MAKSİMUM DİNAMİK TORK	
	GÜÇ – POWER		TORK – TORQUE		GÜÇ – POWER		TORK – TORQUE		MAX DYNAMIC TORQUE	
	KW	HP	Nm	in.lb	KW	HP	Nm	in.lb	Nm	in.lb
1	12	16	210	1850	18	25	172	1500	320	2850
2	15	21	270	2400	23	31	220	1950	450	4000
4	26	35	460	4050	40	55	380	3350	780	6900
5	35	47	620	5500	54	74	520	4600	1050	9300
6	47	64	830	7350	74	100	710	6250	1450	12850
7	55	75	970	8600	87	118	830	7350	1800	15950
8	55	75	970	8600	87	118	830	7350	1800	15950
9	70	95	1240	10950	110	150	1050	9300	2250	19900
J	106	145	1890	16700	170	230	1630	14400	3800	33650
L	121	165	2145	18950	188	255	1795	15850	4390	38850

Değerler 5° mafsal açısına ve 1000 saat çalışma ömrüne göre. Değerler 10° mafsal açısına ve 500 saat çalışma ömrüne göre.

Values related to 5° joint angles, 1000 hours life. Values related to 10° joint angles, 500 hours life.

Geniş açılı şaft 80°
 Wide angle CV PTO drive shafts 80°
 Grand angle homocinétiques 80°
 Weitwinkel-Gleichlauf-Gelenkwellen 80°

50 Hours

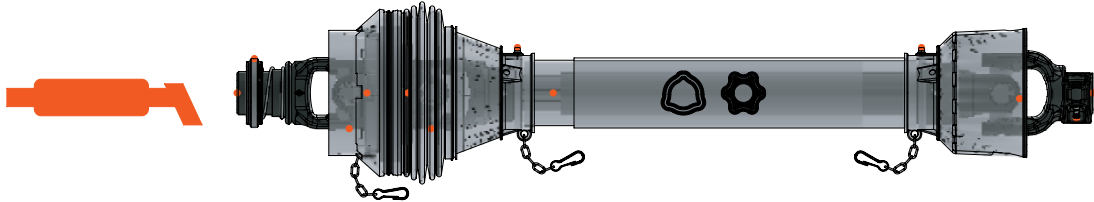

50 Hours

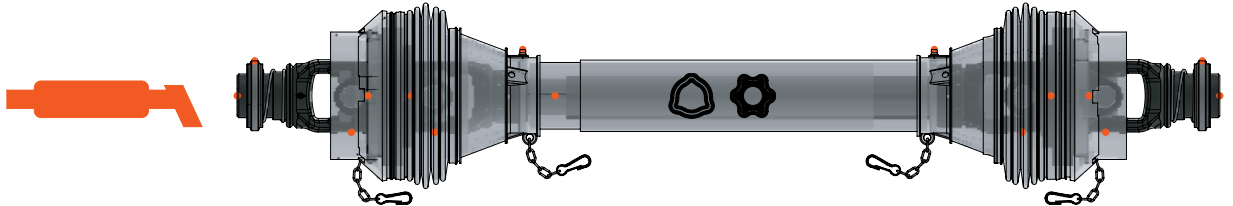

Şaft Serisi Shaft Size Arbre Type Gelenk.Type	540 dev./dak.-rpm			1000 dev./dak.-rpm							*					
	KW	CV HP	Nm	KW	CV HP	Nm	ØA	H	ØA1	H1	ØA	H	A	H	A	H
GA2	20	27	355	31	42	295	Ø22	76	Ø23,8	61,3	Ø23,8	61,3	36,5	4	43,5	3,4
GA4	28	38	500	44	60	415	Ø23,8	91	Ø27	74,6	Ø27	74,6	36,5	4	43,5	3,4
GA6	44	60	780	68	93	653	Ø27	94	Ø32	76	Ø30,2	92	44,5	4	54	4

Şaft Serisi Shaft Size Arbre Type Gelenk.Type	540 dev./dak.-rpm			1000 dev./dak.-rpm							*								
	KW	CV HP	Nm	KW	CV HP	Nm	ØA	H	ØA1	H1	ØA	H	A	B	H	A	B	H	
GA6	44	60	780	68	93	653	Ø27	94	Ø32	76	Ø30,2	92	47	51	24	57	61	4,5	
GA8	66	90	1175	102	139	975	Ø32	106,3	Ø36	89	Ø35	106,3	47	51	24	57	61	4,5	

- *Kaplama boru
- *Rilsan coated tube
- *Tube rilsanisé
- *Rilsan-beschichtetes Rohr

Zirai saftlar
PTO drive shafts
Transmissions
Gelenkwellen

50 Hours

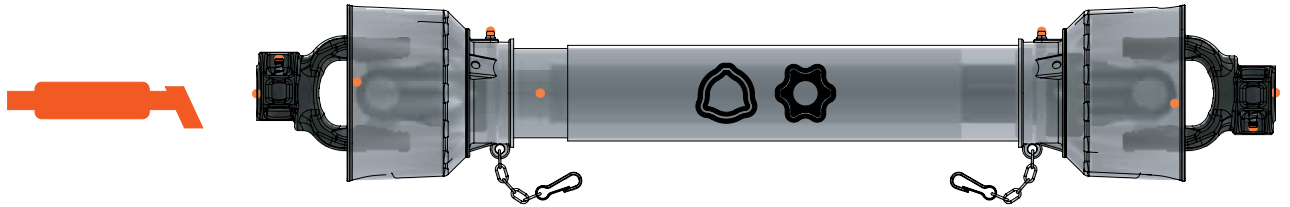

Şaft Serisi Shaft Size Arbre Type Gelenk.Type	540 dev./dak.-rpm			1000 dev./dak.-rpm								
	KW	CV HP	Nm	KW	CV HP	Nm				ØA	H	A
1	12	16	210	18	25	172	Ø22	54	29	4	36	3,2
2	15	21	270	23	31	220	Ø23,8	61,3	29	4	36	3,2
4	26	35	460	40	55	380	Ø27	74,6	36,5	4	43,5	3,4
5	35	47	620	54	74	520	Ø30,2	79,4	44,5	4	51,5	4
6	47	64	830	74	100	710	Ø30,2	92	44,5	4	54	4
7	55	75	970	87	118	830	Ø30,2	106,3	44,5	5	54	4
8	55	75	970	87	118	830	Ø35	93,5	44,5	5	54	4
9	70	95	1240	110	150	1050	Ø35	106,3	44,5	5	54	4

Şaft Serisi Shaft Size Arbre Type Gelenk.Type	540 dev./dak.-rpm			1000 dev./dak.-rpm										
	KW	CV HP	Nm	KW	CV HP	Nm				ØA	H	A	B	H
6	47	64	830	74	100	710	Ø30,2	92	47	51	24	57	61	4,5
7	55	75	970	87	118	830	Ø30,2	106,3	47	51	24	57	61	4,5
8	55	75	970	87	118	830	Ø35	93,5	47	51	24	57	61	4,5
9	70	95	1240	110	150	1050	Ø35	106,3	47	51	24	57	61	4,5
J	106	145	1890	170	230	1630	Ø41	116	57	61	4,5	67	71	5
L	121	165	2145	188	255	1795	Ø48	118	57	61	24	67	71	5

Emniyet kavramaları

Safety devices

Dispositifs de sécurité

Sicherheitselemente

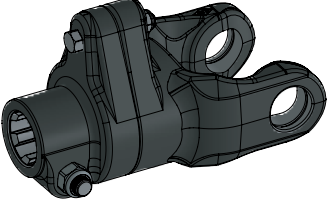

PİM KESER EMNİYET KAVRAMASI
SHEAR BOLT CLUTCH
LIMITEUR BOULON DE RUPTURE
SCHERBOLZENKUPPLUNG

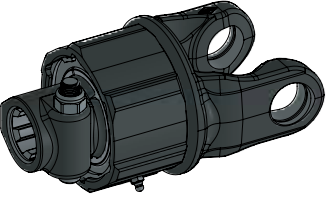

SERBEST GERİ DÖNÜŞÜMLÜ KAVRAMA
OVERRUNNING CLUTCH
ROUE LIBRE
FREILAUFKUPPLUNG

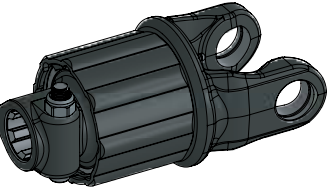

TORK LİMİTLİ
TOEQUE LIMITER
LIMITEUR A CAMES
STERNRATSCHÉ

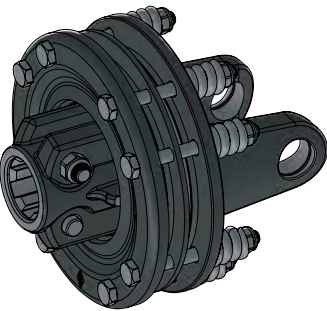

BALATALI KAVRAMA
FRICTION CLUTCH
FRICTION A DISQUES
REIBKUPPLUNG

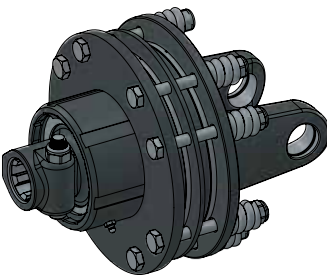

BALATALI & SERBEST DÖNÜŞÜMLÜ
FRICTION DISC &
OVERRUNNING CLUTCH
ROUE LIBRE & FRICTION A
DISQUES
FREILAUFKUPPLUNG &
REIBKUPPLUNG

Çatallar

Yoke

Joug

Gabeln

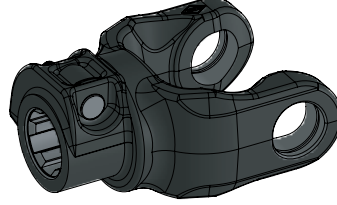

TEK PİMLİ
ONE PUSH PIN
MÂCHOIRE VERROUILLAGE RAPIDE AVEC VERROU
MIT SCHIEBESTIFT

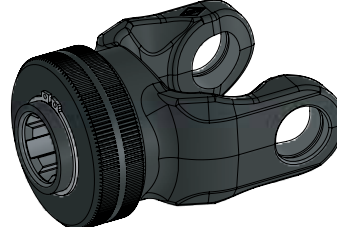

OTOMATİK KİLİTLİ
HANDWHEEL WITH PIN
VOLANT AVEC UN CODE PIN
HANDRAD MIT PIN

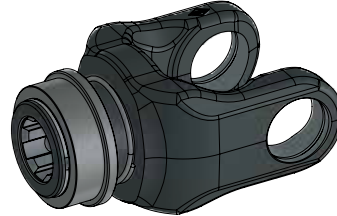

BİLYA KİLİTLİ
WITH BALL ATTACHMENT
MÂCHOIRE À VERROUILLAGE À BILLES
MIT ZIEHVERSCHLUSS

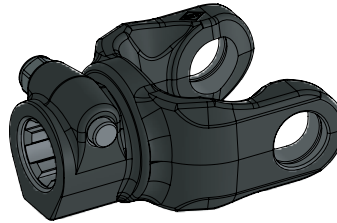

KONİK CİVATALI
TAPER PIN
MÂCHOIRE CANNELÉE A BOULON CONIQUE
MIT KLEMMKONUSBOLZEN

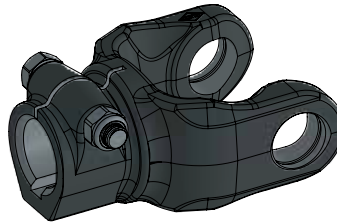

KAMALI YARIKLI
KEYWAY & CLAMP BOLT
MÂCHOIRE CANNELÉE AVEC BOULON TANGENT
MIT KLEMMSCHRAUBE (KRAFTSCHLUSS)

Traktör Kuyruk Mili Standartları
Standard Splines for Agriculture
Splines Standards Pour L'agriculture
Standard Ketten Für Landwirtschaft

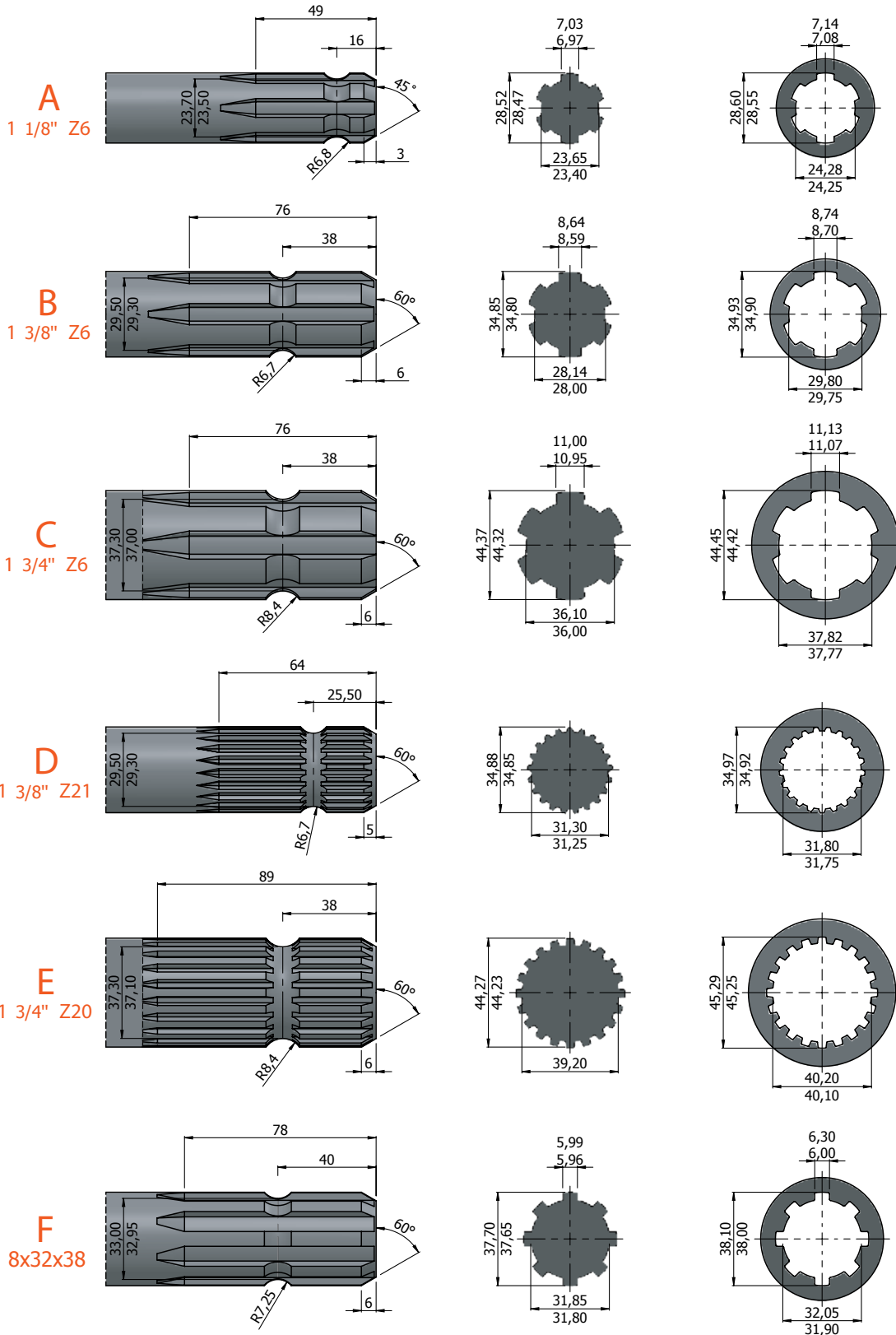

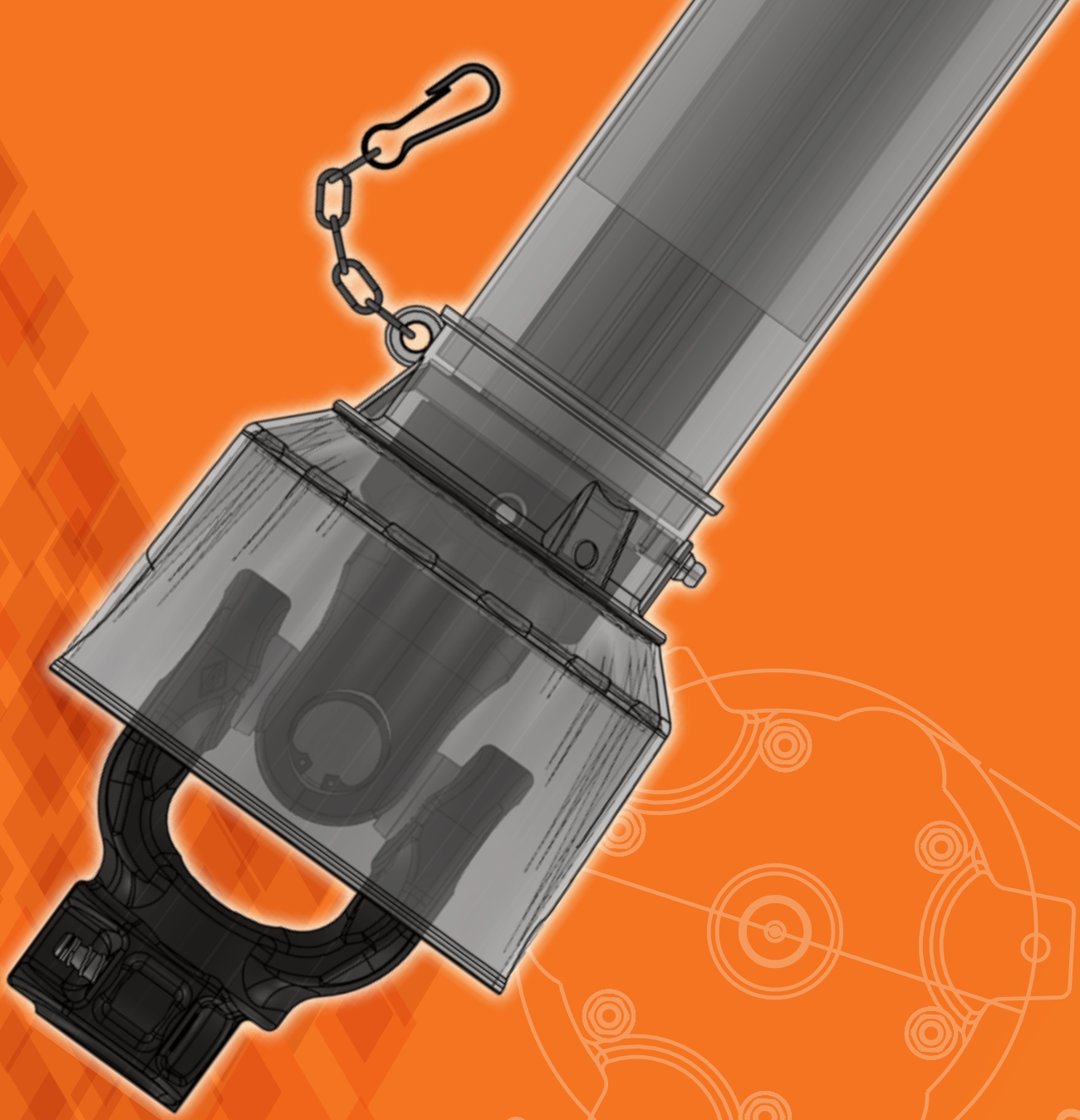

Ø 12,50

260



GENÇSAN KARDAN

Egemenlik Mahallesi 6106/4 Sk. No:42-B Isikkent / IZMIR TURKIYE

Phone : +90 232 437 02 75 +90 232 437 02 74

E-Mail : info@gencsankardan.com Web : www.gencsankardan.com